



**OPERATION & CARE
MANUAL**

P-2010-S

120V



P-2010-S

**BLANKET WARMING CABINET
OPERATION & CARE**

INDEX

Transport and Storage 1
Delivery 1
Unpacking 1
Safety Procedures and Precautions 2

Installation

Preparation 3
Electrical Information 3
General Warnings 4-5
General Information 6
Dimension Drawings, weights & capacities 7

Operating Instructions

Blanket Chamber Operational Procedures 8

Care and Cleaning

Cleaning and Preventative Maintenance 9
Protecting Stainless Steel Surfaces 9
Cleaning Agents 9
Cleaning Materials 9
Care and Cleaning 10
Clean the Unit Regularly 10

Troubleshooting Guide 11

Warranty

Transportation Damage and Claims Back Cover
Limited Warranty Back Cover

BLANKET WARMING CABINET

TRANSPORT AND STORAGE

Transport and Storage Environmental Conditions (not to exceed 15 days)

- Ambient temperature range of -40 to +159°F (-40° to +70°C)
- Relative humidity range of 10% to 100%
- Atmospheric pressure range of 50KPa to 106KPa

UNPACKING AND SET-UP

DELIVERY

The Pedigo Blanket Warming Cabinet has been thoroughly tested and inspected to insure only the highest quality unit is provided. Upon receipt, check for any possible shipping damage and report it at once to the delivering carrier. *See Transportation Damage and Claims section located in this manual.*

This appliance, complete with unattached items and accessories, may have been delivered in one or more packages. Check to ensure that all standard items and options have been received with each model as ordered.

Save all the information and instructions packed with the appliance. Complete and return the warranty card to the factory as soon as possible to assure prompt service in the event of a warranty parts and labor claim.

This manual must be read and understood by all people using or installing the equipment model. Contact the Pedigo service department if you have any questions concerning installation, operation, or maintenance.

NOTE: All claims for warranty must include the full model number and serial number of the unit.

UNPACKING

1. Carefully remove the appliance from the carton or crate.

NOTE: Do not discard the carton and other packaging material until you have inspected the unit for hidden damage and tested it for proper operation.

2. Read all instructions in this manual carefully before initiating the installation of this appliance.

DO NOT DISCARD THIS MANUAL.

This manual is considered to be part of the appliance and is to be provided to the owner or manager of the business or to the person responsible for training operators. *Additional manuals are available from the Pedigo service department.*

3. Remove all protective plastic film, packaging materials, and accessories from the appliance before connecting electrical power.

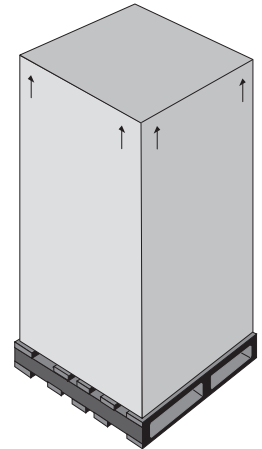

SAFETY PROCEDURES AND PRECAUTIONS

Knowledge of proper procedures is essential to the safe operation of electrically energized equipment. In accordance with generally accepted product safety labeling guidelines for potential hazards, the following signal words and symbols may be used throughout this manual.

 DANGER	Used to indicate the presence of a hazard that will cause severe personal injury, death, or substantial property damage if the warning included with this symbol is ignored.
---	---

 WARNING	Used to indicate the presence of a hazard that can cause personal injury, possible death, or major property damage if the warning included with this symbol is ignored.
--	--

 CAUTION	Used to indicate the presence of a hazard that can or will cause minor or moderate personal injury or property damage if the warning included with this symbol is ignored.
--	--

CAUTION	Used to indicate the presence of a hazard that can or will cause minor personal injury, property damage, or a potential unsafe practice if the warning included with this symbol is ignored.
----------------	--

NOTE:	Used to notify personnel of installation, operation, or maintenance information that is important but not hazard related.
--------------	---

1. Pedigo blanket warmers are intended for warming cotton blankets **ONLY**. No other use for this device is authorized or recommended.
2. This device is intended for use in commercial establishments where all operators are familiar with the purpose, limitations, and associated hazards of this device. Operating instructions and warnings must be read and understood by all operators and users.
3. Any troubleshooting guides, component views, and parts lists included in this manual are for general reference only and are intended for use by qualified technical personnel.
4. This manual should be considered a permanent part of this device. This manual and all supplied instructions, diagrams, schematics, parts lists, notices, and labels must remain with the device if the item is sold or moved to another location.

NOTE
<p>Pedigo warmers should not be left unattended for periods of more than 24 hours. In case of absences longer than 24 hours, disconnect the warmer from its power source.</p>

NOTE	
	<p>For equipment delivered for use in any location regulated by the following directive:</p> <p>DO NOT DISPOSE OF ELECTRICAL OR ELECTRONIC EQUIPMENT WITH OTHER MUNICIPAL WASTE.</p>

PREPARATION

Before operating the cabinet, clean both the interior and exterior of the unit with a damp cloth and mild soap solution. Wipe with an appropriate disinfectant. Clean and install the cabinet basket assembly.

ELECTRICAL INFORMATION



The power specifications are located on the unit identification rating tag. This tag is permanently attached to the unit and must be located to verify power requirements.

UL FILE # <input style="width: 80%;" type="text"/>	MADE IN USA
MODEL <input style="width: 80%;" type="text"/>	
WATTS <input style="width: 80%;" type="text"/>	
VOLTS <input style="width: 20%;" type="text"/> 1 PH <input style="width: 20%;" type="text"/> Hz	
SERIAL# <input style="width: 80%;" type="text"/>	

POWER REQUIREMENTS - P-2010-S

120 V.A.C. — 60 Hz, 1 ph
 500 Watts, 4.1 Amps
 Safety Class I Equipment
 No Applied Parts



NEMA 5-15P
 15A - 125V Plug
 Hospital Grade



NOTE: An electrical wiring diagram for this unit can be found in a sleeve on the bottom side of the top cover of the control.

Trouble shooting for possible EMC interference

- Main power quality should be that of a typical commercial or hospital environment
- Power frequency magnetic fields should be at levels characteristic of a typical location in a commercial or hospital environment

Grounding reliability can only be achieved when equipment is connected to an equivalent receptacle marked "Hospital Grade."



Protective Earth
 Ground Symbol

Medical Equipment classified by Underwriters Laboratories with Respect to Electrical Shock, Fire and Mechanical Hazards only, in Accordance with UL 61010-1 and CAN/CSA C22.2 No. 61010.1



UL File No.
 E471516

DANGER

ENSURE POWER SOURCE MATCHES VOLTAGE STAMPED ON APPLIANCE NAMEPLATE.

DANGER

AT NO TIME SHOULD THE INTERIOR OR EXTERIOR BE STEAM CLEANED, HOSED DOWN, OR FLOODED WITH WATER OR LIQUID SOLUTION OF ANY KIND. DO NOT USE WATER JET TO CLEAN.

SEVERE DAMAGE OR ELECTRICAL HAZARD COULD RESULT.

WARRANTY BECOMES VOID IF APPLIANCE IS FLOODED

GENERAL WARNINGS

The P-2010-S requires special precautions regarding EMC and needs to be installed and put into service according to the EMC information provided below.

Portable and mobile RF communications equipment can affect medical electrical equipment.

WARNING: A risk of increased emissions or decreased immunity may result if the power cord attached is altered or a manufacturer supplied power cable is not used.

The P-2010-S should not be used adjacent to or stacked with other equipment.

WARNING: observe to verify normal operation if it is necessary to use adjacent to or stacked with other equipment.

Guidance and manufacturer's declaration – electromagnetic emissions

The Model P-2010-S is intended for use in the electromagnetic environment specified below. The customer or the end user of the Model P-2010-S should assure that it is used in such an environment.

Emissions test	Compliance	Electromagnetic environment - guidance
RF emissions CISPR 11	Group 1	The Model P-2010-S uses RF energy only for its internal function. Therefore, its RF emissions are very low and are not likely to cause any interference in nearby electronic equipment.
RF emissions CISPR 11	Class B	The Model P-2010-S is suitable for use in all establishments, including domestic establishments and those directly connected to the public low-voltage power supply network that supplies buildings used for domestic purposes.
Harmonic emissions IEC 61000-3-2	Class A	
Voltage fluctuations/Flicker emissions IEC 61000-3-3	Complies	

Guidance and manufacturer's declaration – electromagnetic immunity

The Model P-2010-S is intended for use in the electromagnetic environment specified below. The customer or the end user of the Model P-2010-S should assure that it is used in such an environment.

Immunity test	IEC 60601 test level	Compliance level	Electromagnetic environment - guidance
Electromagnetic discharge (ESD) IEC 61000-4-2	±6 kV contact ±8 kV air	±6 kV contact ±8 kV air	Floors should be wood, concrete or ceramic tile. If floors are covered with synthetic material, the relative humidity should be at least 30%.
Electrical fast transient/burst IEC 61000-4-4	±2 kV for power supply lines ±1 kV for input/output lines	+2 kV for power supply lines	Mains power quality should be that of a typical commercial or hospital environment. The P-2010-S does not have any input/output lines.
Surge IEC 61000-4-5	±1 kV differential mode ±2 kV common mode	±1 kV differential mode ±2 kV common mode	Mains power quality should be that of a typical commercial or hospital environment.
Voltage dips, short interruptions and voltage variations on power supply input lines IEC 61000-4-11	<5 % UT (>95 % dip in UT) for 0.5 cycle 40 % UT (60 % dip in UT) for 5 cycles 70 % UT (30 % dip in UT) for 25 cycles <5 % UT (>95 % dip in UT) for 5 sec	<5 % UT (>95 % dip in UT) for 0.5 cycle 40 % UT (60 % dip in UT) for 5 cycles 70 % UT (30 % dip in UT) for 25 cycles <5 % UT (>95 % dip in UT) for 5 sec	Mains power quality should be that of a typical commercial or hospital environment. If the user of the Model P-2010-S requires continued operation during power mains interruptions, it is recommended that the Model P-2010-S be powered from an uninterruptible power supply or a battery.
Power frequency (50/60 Hz) magnetic field IEC 61000-4-8	3 A/m	3 A/m	Power frequency magnetic fields should be at levels characteristic of a typical location in a typical commercial or hospital environment.

NOTE UT is the a.c. mains voltage prior to application of the test level.

The essential performance of the P-2010-S is to not exceed internal temperature of 250 degrees F (+10%) at any setting.

Guidance and manufacturer's declaration - electromagnetic emissions

The Model P-2010-S is intended for use in the electromagnetic environment specified below. The customer or the end user of the Model P-2010-S should assure that it is used in such an environment. The P-2010-S is intended for use in the electromagnetic environment specified below. The customer or the user of the P-2010-S should assure that it is used in such an environment.

Immunity test	IEC 60601 test level	Compliance level	Electromagnetic environment - guidance
Conducted RF IEC 61000-4-6	3 Vrms 150 kHz to 80 MHz	3 V	Portable and mobile RF communications equipment should be used no closer to any part of the P-2010-S, including cables, than the recommended separation distance calculated from the equation applicable to the frequency of the transmitter. Recommended separation distance $d = [3.5/3] \sqrt{P}$ $d = [3.5/3] \sqrt{P}$ 80 MHz to 800 MHz $d = [7/3] \sqrt{P}$ 800 MHz to 2.5 GHz where P is the maximum output power rating of the transmitter in watts (W) according to the transmitter manufacturer and d is the recommended separation distance in metres (m). Field strengths from fixed RF transmitters, as determined by an electromagnetic site survey, ^a should be less than the compliance level in each frequency range. ^b Interference may occur in the vicinity of equipment marked with the following symbol: 
Radiated RF IEC 61000-4-3	3 V/m 80 MHz to 2.5 GHz	3 V/m	

NOTE 1 At 80 MHz and 800 MHz, the higher frequency range applies.

NOTE 2 These guidelines may not apply in all situations. Electromagnetic propagation is affected by absorption and reflection from structures, objects and people.

^a Field strengths from fixed transmitters, such as base stations for radio (cellular/cordless) telephones and land mobile radios, amateur radio, AM and FM radio broadcast and TV broadcast cannot be predicted theoretically with accuracy. To assess the electromagnetic environment due to fixed RF transmitters, an electromagnetic site survey should be considered. If the measured field strength in the location in which the P-2010-S is used exceeds the applicable RF compliance level above, the P-2010-S should be observed to verify normal operation. If abnormal performance is observed, additional measures may be necessary, such as reorienting or relocating the P-2010-S.

^b Over the frequency range 150 kHz to 80 MHz, field strengths should be less than [VI] V/m.

Guidance and manufacturer's declaration – electromagnetic immunity Recommended separation distance between portable and mobile RF communications equipment and the model P-2010-S

The model P-2010-S is intended for use in an electromagnetic environment in which radiated RF disturbances are controlled. The customer or the user of the Model P-2010-S can help prevent electromagnetic interference by maintaining a minimum distance between portable and mobile RF communications equipment (transmitters) and the Model P-2010-S as recommended below, according to the maximum output power of the communications equipment.

Rated maximum output power of transmitter W	Separation distance according to frequency of transmitter m		
	150 kHz to 80 MHz	80 MHz to 800 MHz	800 MHz to 2.5 GHz
	$d = \left[\frac{7}{3} \right] \sqrt{P}$	$d = \left[\frac{3.5}{3} \right] \sqrt{P}$	$d = \left[\frac{7}{3} \right] \sqrt{P}$
0.01	0.117	0.117	0.233
0.1	0.369	0.369	0.738
1	1.167	1.167	2.333
10	3.689	3.689	7.379
100	11.667	11.667	23.333

For transmitters rated at a maximum output power not listed above, the recommended separation distance d in meters (m) can be estimated using the equation applicable to the frequency of the transmitter, where P is the maximum output rating of the transmitter in watts (W) according to the transmitter manufacturer.

NOTE 1 At 80 MHz and 800 MHz, the separation distance for the higher frequency range applies.

NOTE 2 These guidelines may not apply in all situations. Electromagnetic propagation is affected by absorption and reflection from structures, objects and people.

GENERAL INFORMATION

This warming cabinet is designed to elevate and maintain blanket temperatures to a level which will increase patient comfort.

2.3 cubic feet of capacity in a single cavity countertop warming cabinet with 20 gauge stainless steel exterior and door with handle and hinges designed to withstand heavy usage. The cabinet is equipped with low-heat-density electrothermal cable mounted against the walls, eliminating the need for a heat circulating fan. Interior contains one (1) epoxy-coated blanket support assembly. The cabinet is furnished with four (4) non-skid rubber feet.

The cabinet is controlled by one (1) ON/OFF power switch and a temperature control knob that is adjustable from 16°C (60°F) to 92°C (200°F). The unit includes a digital display, and a temperature display light that indicates that the cabinet has reached the desired warming temperature.

DANGER



AT NO TIME SHOULD THE INTERIOR OR EXTERIOR BE STEAM CLEANED, HOSED DOWN, OR FLOODED WITH WATER OR LIQUID SOLUTION OF ANY KIND. DO NOT USE WATER JET TO CLEAN.



SEVERE DAMAGE OR ELECTRICAL HAZARD COULD RESULT.

WARRANTY BECOMES VOID IF APPLIANCE IS FLOODED

NOTE

The temperature inside the warmer's cavity shall never exceed maximum permissible temperature plus the tolerance. (250°F [121°C] +10%)

NOTE

**Environmental conditions for operation:
Maximum ambient room temperature of 89°F (32°C).**



DANGER



DO NOT use this warming cabinet in the presence of flammable anesthetic mixture (with air or with oxygen or nitrous oxide). THIS COULD RISK AN EXPLOSION!

DIMENSIONS

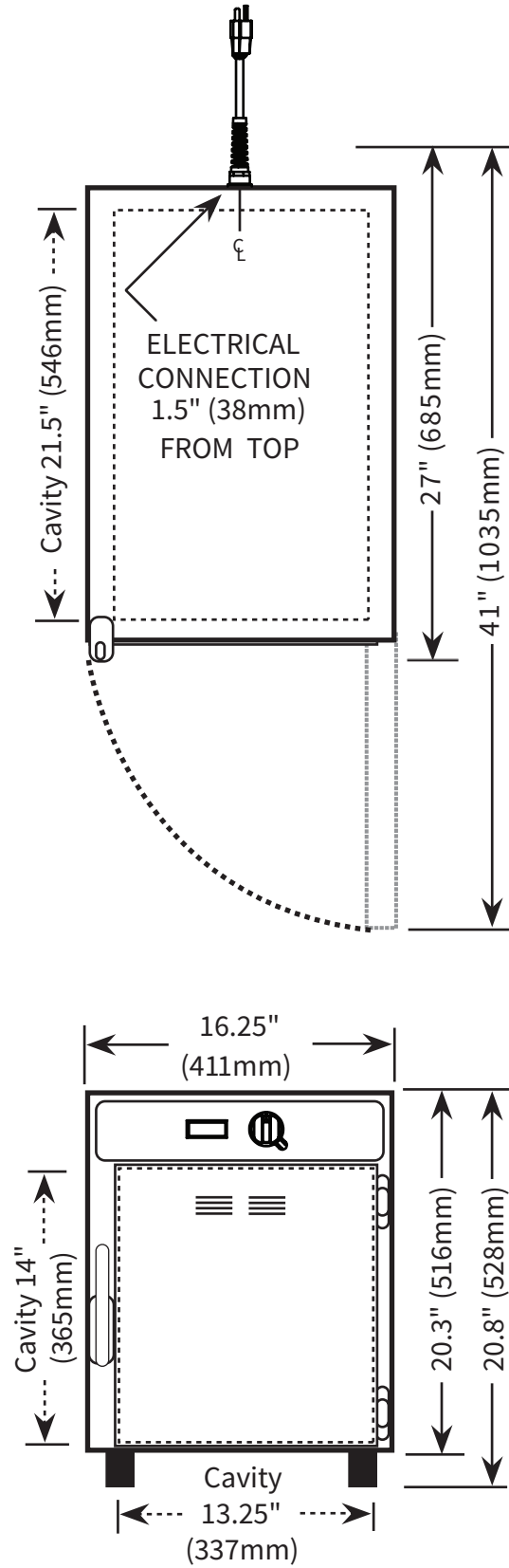

OPERATIONAL PROCEDURES

1. The appliance should be plugged into a hospital grade, NEMA 5-15P receptacle. The unit requires 1" (25mm) clearance on sides, back, and bottom.

2. Turn on the power circuit breaker switch, which is located at the back of the appliance. It is a rocker-type switch with international ON (I) and OFF (O) markings.

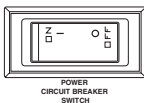

3. PREHEAT AT 200°F (93°C).

Rotate the control knob to 200°F (93°C). The Set temperature will appear in the digital display and the temperature display light will illuminate. Press the Temperature Display Button at any time to display the Actual inside air temperature.

To toggle between Set and Actual Temperatures:

Factory default is to display Set temperature in the digital display. To display Actual temperature:

1. With the control ON, press and hold the Temperature Display Button for 5 seconds. The control will show **ACT**, then show the Actual temperature.
2. Repeat to toggle to Set point **SET**.
3. Press the Temperature Display Button at any time to display the alternate temperature.

To toggle between Fahrenheit and Celsius:

The factory default is Fahrenheit. To change to Celsius:

1. With the control OFF (i.e. Temperature Control Knob set to the OFF position), press and hold the Temperature Display button for 5 seconds.
2. The control will show **°C** for 3 seconds to verify selection and then show the temperature in °C.
3. Repeat to toggle to Fahrenheit.

Note: With a power failure, the control will retain the °C or °F setting selected by the user when power is restored.

4. The temperature display LED will illuminate when the control is heating the unit.

5. LOAD THE CHAMBER WITH 100% COTTON BLANKETS. DO NOT WARM SYNTHETIC BLEND FABRICS OR ITEMS CONTAINING PLASTIC, RUBBER OR METAL SNAPS, STUDS, HOOKS, ETC.

Check that the epoxy-coated blanket support assembly is in place. This blanket support assembly **MUST** be used to hold blankets. A full load of blankets will take 1-2 hours to reach optimum temperature. Make certain the cabinet door is securely closed after initial loading and following each blanket removal.

Note: Do not block sensor by overloading cabinet with blankets.

6. ROTATE LOAD OF BLANKETS DAILY.

Rotate the blankets at the bottom of the load to the top to ensure equal usage. Failure to rotate blankets can cause blankets to discolor.

Note: Avoid using flammable cabinet cleaning agents, as well as blanket cleaning agents that cause fabric to become brittle over time.

CAUTION

**BLANKET SUPPORT ASSEMBLY AND SHELF
MUST BE USED WHEN WARMING BLANKETS.**

CAUTION

**DO NOT OVERLOAD CABINET.
BLANKETS MUST NOT EXCEED HEIGHT OF
SUPPORT ASSEMBLY. ALLOW 1" GAP
BETWEEN LOWER BLANKETS AND SHELF.**

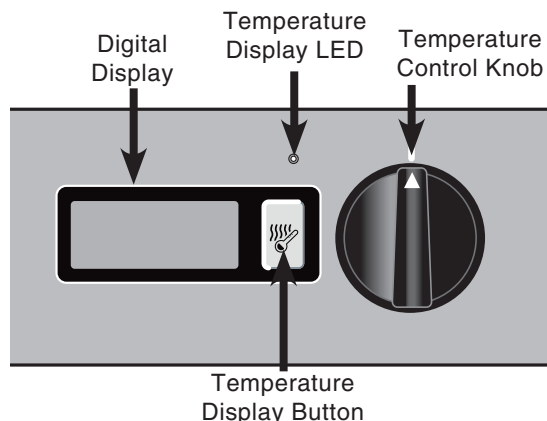

CLEANING AND PREVENTIVE MAINTENANCE

PROTECTING STAINLESS STEEL SURFACES



It is important to guard against corrosion in the care of stainless steel surfaces. Harsh, corrosive, or inappropriate chemicals can completely destroy the protective surface layer of stainless steel. Abrasive pads, steel wool, or metal implements will abrade surfaces

causing damage to this protective coating and will eventually result in areas of corrosion. Even water, particularly hard water that contains high to moderate concentrations of chloride, will cause oxidation and pitting that result in rust and corrosion. In addition, many acidic spills left to remain on metal surfaces are contributing factors that will corrode surfaces.

Proper cleaning agents, materials, and methods are vital to maintaining the appearance and life of this appliance. Spilled items should be removed and the area wiped as soon as possible but at the very least, a minimum of once a day. Always thoroughly rinse surfaces after using a cleaning agent and wipe standing water as quickly as possible after rinsing.

CLEANING AGENTS

Use non-abrasive cleaning products designed for use on stainless steel surfaces. Cleaning agents must be chloride-free compounds and must not contain quaternary salts. Never use hydrochloric acid (muriatic acid) on stainless steel surfaces. Always use the proper cleaning agent at the manufacturer's recommended strength. Contact your local cleaning supplier for product recommendations.

CLEANING MATERIALS



The cleaning function can usually be accomplished with the proper cleaning agent and a soft, clean cloth. When more aggressive methods must be employed, use a non-abrasive scouring pad on difficult areas and make certain to scrub with the visible grain of surface metal to avoid surface scratches. Never use wire brushes, metal scouring pads, or scrapers to remove residue.



ANNUAL PREVENTATIVE MAINTENANCE

1. Ensure that the correct Operation and Care Manual is available to all users.
2. Ensure that all users have been properly trained in unit's operation.
3. Do not exceed the unit's capacity.
4. Inspect condition of plug and cord. Replace if damaged.
5. Clean dust from outer vents surrounding the unit and around top of bonnet.
6. Check door gasket integrity. Are there any tears? Is the gasket worn or loose? Make sure seal is tight to unit body. Replace gasket if integrity is compromised.
7. Check air temperature sensor mount on the interior of chamber. Is the metal guard in place? Are the wires in good condition?
8. Check the blanket support assembly and shelf (if applicable). Is the assembly in place? Are any pieces missing?
9. Check basket and side rail condition (if applicable). Do baskets move smoothly and freely?
10. Check caster or leg condition. Ensure mounting bolts and assembly is secure.
11. Check control panel overlay condition. Are there any tears or excessive wear on the graphic? Does the control work properly when buttons are pushed?
12. Check that all control LEDs light up as applicable.
13. Is the Set Temperature comparable to the Actual temperature displayed? If not, control needs calibration. Call Service.

Contact Service for immediate repair if any of the above problems exist.

 CAUTION	
	TO PROTECT STAINLESS STEEL SURFACES, COMPLETELY AVOID THE USE OF ABRASIVE CLEANING COMPOUNDS, CHLORIDE BASED CLEANERS, OR CLEANERS CONTAINING QUATERNARY SALTS. NEVER USE HYDROCHLORIC ACID (MURIATIC ACID) ON STAINLESS STEEL. NEVER USE WIRE BRUSHES, METAL SCOURING PADS OR SCRAPERS.
	
	

CARE AND CLEANING

The cleanliness and appearance of this equipment will contribute considerably to its operating efficiency. Make certain the cabinet and door gasket are kept free of any debris that may accumulate. Good equipment that is kept clean works better and lasts longer.



CLEAN THE UNIT REGULARLY:

1. Disconnect the cabinet from the power source.
2. Remove all detachable items such as blanket support assembly and shelf. Clean these items separately.

NOTE: Avoid the use of abrasive cleaning compounds, chloride based cleaners, or cleaners containing quaternary salts. Never use hydrochloric acid (muriatic acid) on stainless steel.



3. Clean the interior metal surfaces of the cabinet with a damp cloth and any mild commercial detergent. Avoid the use of abrasive cleaning compounds. Rinse surfaces by wiping with sponge & clean warm water. Remove excess water with sponge and wipe dry with a clean cloth or air dry. Leave doors open until interior is completely dry.
4. Interior can be wiped with a sanitizing solution after cleaning and rinsing. This solution must be approved for use on stainless steel surfaces. Replace blanket support assembly.
5. Clean the exterior of the cabinet with a cleaner recommended for stainless steel surfaces. Spray the cleaner on a clean cloth and wipe with the grain of the stainless steel.
6. Clean the window glass with a standard commercial glass cleaner.
7. Wipe control panel, door vents, door handles, and door gaskets thoroughly since these areas harbor debris.
8. Wipe door gaskets and control panel dry with a clean, soft cloth.
9. To help maintain the protective film coating on polished stainless steel, clean the exterior of the cabinet with a cleaner recommended for stainless steel surfaces. Spray the cleaning agent on a clean cloth and wipe with the grain of the stainless steel.

Always follow appropriate state or local health (hygiene) regulations regarding all applicable cleaning and sanitation requirements.

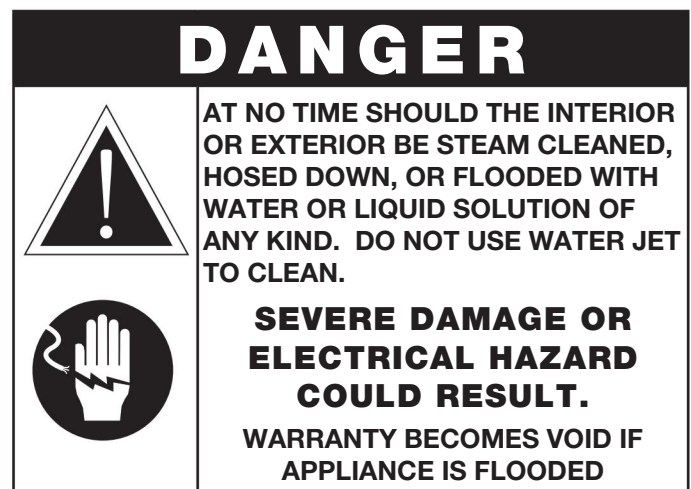
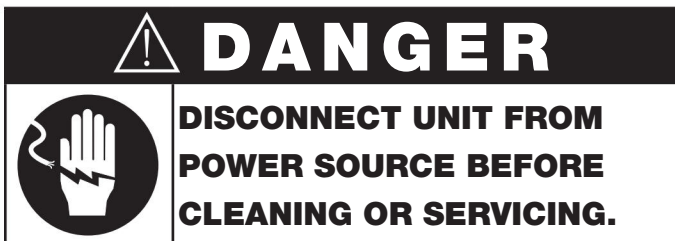

(Listed as Ordinary Equipment.)

TROUBLESHOOTING ERROR CODES

Error Code	Description/Results	Possible Cause Service Required
E-10	Air Sensor Fault (shorted) <i>Inoperative Unit</i>	Air sensor is shorted. Air sensor defective? Test air sensor by placing sensor in ice water bath 32°F (0°C) and using an ohmmeter set on the ohm scale. The reading should be 1000 ohms resistance. If it is more than 20 ohms higher or lower, sensor needs to be replaced. If Ohm reading is 1000, replace display. If Ohm reading is not 1000, replace sensor.
E-11	Air Sensor Fault (open) <i>Inoperative Unit</i>	Air sensor is open or connection failure. Air sensor defective? See above for air sensor test.
E-30	Under temperature <i>Oven will not reach set temperature</i>	Unit door closed? Does door gasket need replacement? Defective air sensor or probe? Defective solid state relay? Bad wire connections or open heating cable? If none of the above, contact Pedigo Service Department.
E-31	Over temperature <i>Unit will shut down</i>	Unit has exceeded its maximum allowable set temperature by 25 degrees for at least 3 minutes. Unit will shut down. Defective sensor or poor sensor connection? Defective relay? Shorted heater element? If none of the above, contact Pedigo Service Department.
E-70	Configuration error <i>Inoperative Unit</i>	Check wire diagram for correct DIP switch settings. (Diagram is located under the unit's top cover behind the control.) If error code persists, contact Pedigo Service Department.
E-82 or E-83	EEPROM Error - Bad Checksum <i>Inoperative Unit</i>	Contact Pedigo Service Department for help resetting the control.
E-90	Button shorted <i>Inoperative Control</i>	Stuck button on control panel. Check buttons. If control is still inoperative, contact Pedigo Service Department.
E-91	Input failure	Contact Pedigo Service Department.
-AC-	Power Failure	Press any key to acknowledge.

TRANSPORTATION DAMAGE AND CLAIMS



All Pedigo Products, Inc. equipment is sold F.O.B. shipping point, and when accepted by the carrier, such shipments become the property of the consignee.

Should damage occur in shipment, it is a matter between the carrier and the consignee. In such cases, the carrier is assumed to be responsible for the safe delivery of the merchandise, unless negligence can be established on the part of the shipper.

1. Make an immediate inspection while the equipment is still in the truck or immediately after it is moved to the receiving area. Do not wait until after the material is moved to a storage area.
2. Do not sign a delivery receipt or a freight bill until you have made a proper count and inspection of all merchandise received.
3. Note all damage to packages directly on the carrier's delivery receipt.
4. Make certain the driver signs this receipt. If he refuses to sign, make a notation of this refusal on the receipt.
5. If the driver refuses to allow inspection, write the following on the delivery receipt:

Driver refuses to allow inspection of containers for visible damage.
6. Telephone the carrier's office immediately upon finding damage, and request an inspection. Mail a written confirmation of the time, date, and the person called.
7. Save any packages and packing material for further inspection by the carrier.
8. Promptly file a written claim with the carrier and attach copies of all supporting paperwork.

We will continue our policy of assisting our customers in collecting claims which have been properly filed and actively pursued. We cannot, however, file any damage claims for you, assume the responsibility of any claims, or accept deductions in payment for such claims.

PEDIGO PRODUCTS, INC. LIMITED WARRANTY

Pedigo Products, Inc. warrants to the original purchaser that any original part that is found to be defective in material or workmanship will, at our option, subject to provisions hereinafter stated, be replaced with a new or rebuilt part.

The labor warranty remains in effect one (1) year from installation or fifteen (15) months from the shipping date, whichever occurs first.

The parts warranty remains in effect three (3) years from installation or thirty-nine (39) months from the shipping date, whichever occurs first.

This warranty does not apply to:

1. Calibration
2. Equipment damage caused by accident, shipping, improper installation or alteration.
3. Equipment used under conditions of abuse, misuse, carelessness or abnormal conditions including equipment subjected to harsh or inappropriate chemicals including but not limited to compounds containing chloride or quaternary salts, poor water quality, or equipment with missing or altered serial numbers.
4. Any losses or damage resulting from malfunction, including loss of contents or consequential or incidental damages of any kind.
5. Equipment modified in any manner from original model, substitution of parts other than factory authorized parts, removal of any parts including legs, or addition of any parts.
6. Collateral or incidental damage as a direct result of servicing equipment built into a wall structure is not covered under warranty. It is the responsibility of the owner to bear all expense related to structural repairs including, but not limited to, external electrical connections and wiring, and the removal or replacement of caulk, grout, tile, or wall covering of any kind. A service access panel for built-in equipment installations is strongly recommended.

This warranty is exclusive and is in lieu of all other warranties, expressed or implied, including the implied warranties of merchantability and fitness for purpose. In no event shall the Company be liable for loss of use, loss of revenue, or loss of contents or revenue, or for indirect or consequential damages. This warranty is in lieu of all other warranties expressed or implied and Pedigo Products, Inc. neither assumes or authorizes any persons to assume for it any other obligation or liability in connection with Pedigo Products, Inc. equipment.

Pedigo Products, Inc.

Record the model and serial numbers of the unit for easy reference. Always refer to both model and serial numbers in your correspondence regarding the unit.

Model: _____
Serial Number: _____
Purchased From: _____
Date Installed: _____ Voltage: _____



Pedigo Products, Inc
4000 S.E. Columbia Way • Vancouver, WA 98661 • U.S.A.
Phone: 800.822.3501 • Fax: 360.696.1700 • www.pedigo-usa.com

