

manual

operation & care

ivNow[®]

individual warming pods



ivNow-1

ivNow-2

ivNow-3

120V / 220v / 230v

Delivery	1
Transportation and Damage Claims.....	2
Unpacking.....	2
Safety Procedures	3
Installation	4
Dimensions.....	5
Electrical Connection	6
Operation.....	7
Cleaning and Preventative Maintenance	10
Troubleshooting	11

Environmental Conditions

Transport and storage environmental conditions (not to exceed 15 days)

Ambient temperature range of -40°C to +70°C (-40°F to +159°F)

Relative humidity range of 10% to 95%, non-condensing

Atmospheric pressure range of 50kPa to 106kPa

Operational environmental conditions

The appliance must acclimate to the room temperature in the environment it will be placed—24 hours is recommended

The recommended environmental temperature range is 15°C to 32°C (60°F to 90°F)

The recommended relative humidity is above 20%, non-condensing.

Receipt of Appliance

The appliance has been thoroughly tested and inspected to ensure only the highest quality appliance is provided. Upon receipt, inspect for any possible shipping damage and report it at once to the delivering carrier. See **Transportation Damage and Claims** section.

This appliance, complete with unattached items and accessories, may be delivered in one or more packages. Confirm that all standard items and options have been received with each appliance as ordered. Save all the information packed with the appliance.



Indicates that the package contents should not be used if the package has been damaged or opened.

1. Carefully remove the appliance from the carton.

NOTE: Do not discard the carton and other packaging material until you have inspected the unit for hidden damage and tested it for proper operation.

Should damage occur in shipment, do not put the warmer into service until the damage has been inspected by an authorized service provider







Promptly contact Pedigo customer service to report damage.

2. Read all instructions in this manual carefully before initiating the installation of this appliance.

Do not discard this manual. This manual is considered to be part of the appliance and is to be provided to the owner or manager of the business or to the person responsible for training operators. Additional manuals are available from the Pedigo service department or online at www.pedigo-usa.com.

3. Remove all protective plastic film, packaging materials, and accessories from the appliance before connecting electrical power.

Knowledge of proper procedures is essential to the safe operation of electrically energized appliances. The following hazard signal words and symbols may be used throughout this manual.

DANGER	
	Used to indicate the presence of a hazard that will cause severe personal injury, death, or substantial property damage if the warning included with this symbol is ignored.
WARNING	
	Used to indicate the presence of a hazard that CAN cause personal injury, possible death, or major property damage if the warning included with this symbol is ignored.
CAUTION	
	Used to indicate the presence of a hazard that can or will cause minor or moderate personal injury or property damage if the warning included with this symbol is ignored.
	Used to indicate that referral to operating instructions is a mandatory action. If not followed, the operator or patient could suffer personal injury.
	Used to indicate that referral to operating instructions is recommended to understand operation of the appliance.
NOTICE: Used to notify personnel of installation, operation, or maintenance information that is important but not hazard related.	
	NOTICE: For appliances delivered for use in any location regulated by the following directive (2012/19/EU -WEEE): Do not dispose of electrical or electronic appliances with other municipal waste.

- Fluid warmers are only intended for warming medical solutions for irrigation and injection prior to use. Refer to the labeling of the manufacturer of the products to be warmed regarding the recommended temperature and the duration of warming. No other use for this appliance is authorized or recommended.
- If the equipment is used in a manner not specified by the manufacturer, the protection provided by the equipment may be impaired.
- Appliance must be accessible. Do not place the appliance in a location where it is difficult to unplug.
- This warmer is intended for use in commercial establishments where all operators are familiar with the purpose, limitations, and associated hazards of this appliance. The warmer can be used wherever there is appropriate space and electrical source including patient support areas, ER, ICU, PACU, surgical suites, patient rooms, and nursing stations. Do not use the warmer in the presence of flammable anesthetic mixtures (with air, oxygen, or nitrous oxide).
- Operating instructions and warnings must be read and understood by all operators and users.
- Any troubleshooting guides, component views, and parts lists included in this manual are for general reference only and are intended for use by qualified and trained technicians.
- This manual should be considered a permanent part of this appliance. This manual and all supplied instructions, diagrams, schematics, parts lists, notices, and labels must remain with the appliance if the item is sold or moved to another location.

How to Install/Mount the ivNow

ivNow modular units can be installed in a variety of ways.

Up to 3 units can be linked together with a jumper cord and connected via a mounting plate. Configurations can be placed on counter top, mounted to wall or pole.

The rear bracket provided with the ivNow can be used to mount the pod(s) to the wall. See mounting instructions on page 5.

Note: Rear bracket provided with the ivNow is not required for countertop single pod configuration. For other mounting options (i.e. Horizontal Rails or roll stands) refer to the instructions included with the mounting kit.

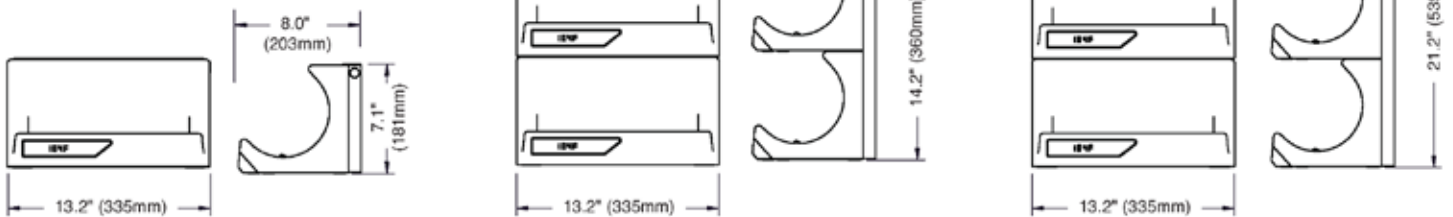
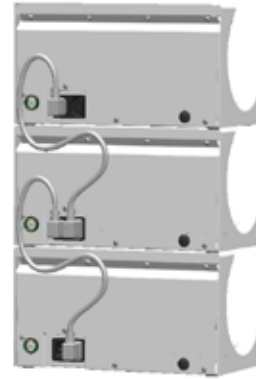

Mounting Instructions

①

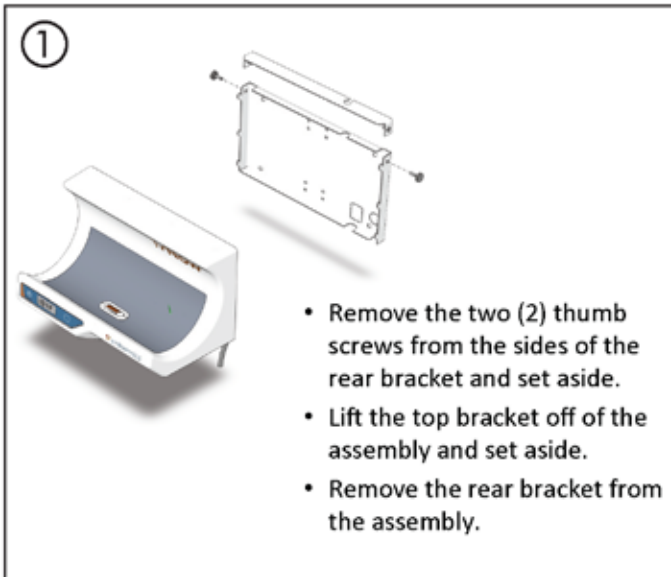

- Remove the two (2) thumb screws from the sides of the rear bracket and set aside.
- Lift the top bracket off of the assembly and set aside.
- Remove the rear bracket from the assembly.

②

- Mount the rear plate to the wall using 1/4" toggle bolts and washers.

Note: For drywall mounting, drywall must be a minimum thickness of 1/2"

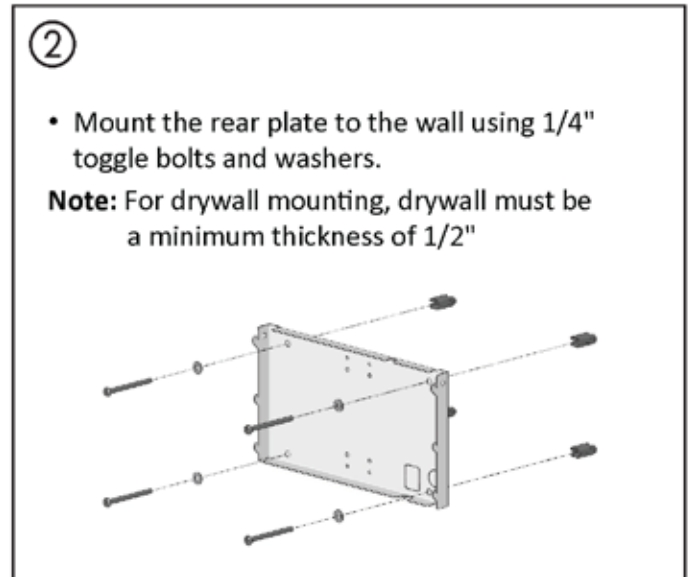

③

- Use the panel as a template for the hole locations

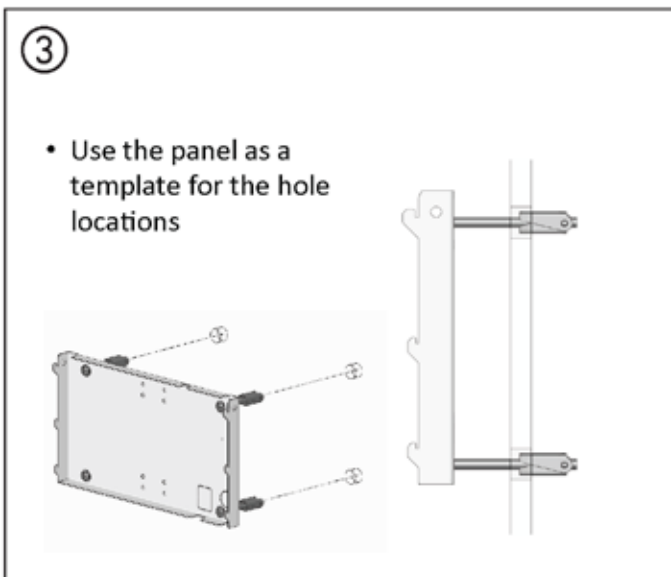

④

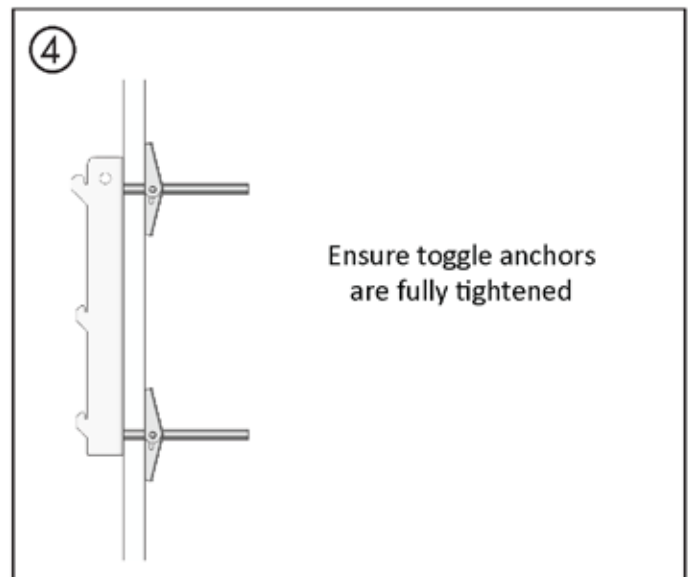

Ensure toggle anchors are fully tightened

⚠ DANGER



To prevent serious personal injury, death, or property damage:

Do not use this warmer in the presence of flammable anesthetic mixtures (with air or with oxygen or nitrous oxide).

Not category AP or APG equipment

⚠ CAUTION



Power source must match voltage identified on appliance rating tag. The rating tag provides essential technical information required for any appliance installation, maintenance or repairs. Do not remove, damage or modify the rating tag.

ivNow Power Requirements

120/220/230 V A C — 50/60 Hz, 1 ph
100W per pod (maximum of 400W
with 4 connected pods)
Safety Class I Equipment
No Applied Parts
Mode of Operation: Continuous



NEMA 5-15P
15A - 125V Plug
Hospital Grade

Applicable only on units with an equipotential-bonding terminal:

To prevent an electrical shock hazard between the appliance and other appliances or metal parts in close vicinity, an equipotential-bonding terminal is provided. An equalization bonding lead must be connected to this stud and the other appliances / metal parts to provide sufficient protection against potential difference. The terminal is marked with the following symbol.



Grounding reliability can only be achieved when equipment is connected to an equivalent receptacle marked "Hospital Grade."

Electrical Information



The power specifications are located on the unit identification nameplate. This nameplate is permanently attached to the unit and must be located to verify power requirements.

General Information

The ivNow fluid warmer quickly warms and maintains the temperature of injection/intravenous solutions prior to their use. The specially contoured warming module cradles solution bags in 0.5-, 1-, 2- & 3-liter sizes. The control can easily be set to display temperatures in Celsius or Fahrenheit. A sensor in the heating plate detects the presence of a bag and engages the heating mechanism to quickly begin warming the fluid. Two (2) temperature sensors work in unison to precisely and continuously read the temperature of the bag and another sensor monitors the plate temperature. The heater will reengage as necessary to maintain the temperature within $+0/-2^{\circ}\text{C}$ ($+0/-3^{\circ}\text{F}$) of the setpoint. The electronic control monitors the length of time the bag has been held at temperature, beginning when the bag reaches setpoint temperature. The display shows the time the fluid has been held at temperature.

NOTE: In the event that fluid should spill inside the cavity, unplug the unit to prevent an electrical shock hazard. Wipe excess fluid from module immediately. Refer to qualified service personnel. Qualified service personnel should remove the module control and remove any remaining liquid. Perform necessary hospital electrical safety checks before returning the unit to operation.

ivNow Capacity Information

The ivNow warming module accommodates fluids packaged in bags. Each warming module cradles solution bags in 0.5-, 1-, 2- and 3-liter sizes.

Safety Feature

- The control of the ivNow is designed to display an error message (E-31) and stop heating if the temperature of the fluid bag (as monitored by the dual sensor switch) is ever above 40°C (104°F).
- The control also monitors the temperature of the aluminum and limits the temperature to a maximum of 60°C (140°F).
- There are two protective devices wired in series with the heating element; an automatic thermostat and a thermal fuse that disconnect the power to the heating element if the plate exceeds 65°C (149°F) and 84°C (183°F) respectively, in the event of a run away condition.

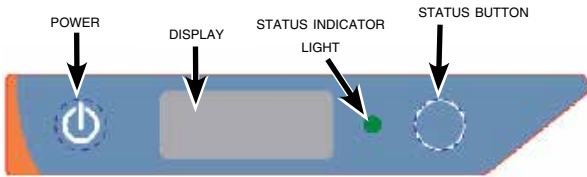

Operating Instructions

1. Before operating the module(s), clean the exterior of the unit with a damp cloth and general hospital cleaner (isopropyl alcohol).
2. Plug the appliance into an appropriate hospital-grade receptacle. See the appliance data tag for voltage requirements.
3. Turn ON by pressing the power button located on the front of the warmer. When on, the control display will be powered. The plate will not heat until a bag is placed in module.
4. Activate control by placing bag of fluid in module. See Figure 1. For optimum performance, the bag should be centered over the sensor.

NOTE: The warm-up stabilization time will vary slightly depending on the bag temperature and ambient room temperature.

5. The display will continue to show the current bag temperature as the fluid is heated.
6. The green status indicator will illuminate when the fluid is within $\pm 2^{\circ}\text{C}$ ($\pm 3^{\circ}\text{F}$) of the setpoint temperature.

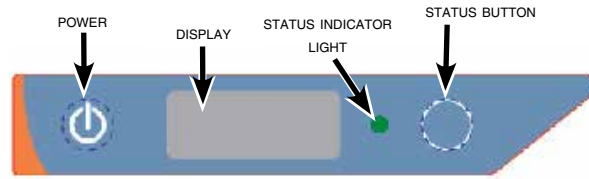

ivNow Status Indicators

Fluid bag is not present

The DISPLAY will show 4 dashes.

Fluid bag detected, measuring initial bag temperature

The DISPLAY will show a chasing dash.

Warming the fluid bag

The DISPLAY will show the current bag temperature.

Fluid bag temperature is within tolerance

The STATUS INDICATOR LIGHT will be illuminated and DISPLAY will show the current bag temperature.

Fluid bag temperature is over set point

The DISPLAY will flash current bag temperature. The display will continue flashing until the temperature falls below the set point. Do not use fluid bag until the display stops flashing.

Fluid bag heated residence time is in excess of limit

The DISPLAY will flash the word "DATE". ivNow will monitor the time spent continuously heating a fluid bag and notify the user that the time limit has been exceeded. Remove the fluid bag from the warmer and check the expiration date. Discard fluid if expired.

Internal error is detected

The DISPLAY will show an error code starting with "E-" followed by a number. Refer to the Troubleshooting Guide for the error code description.

Display the set temperature

Press the STATUS button to show the set temperature.

Display the time spent at the set temperature

Press and hold the STATUS button for 2 seconds to see how long a bag has been at the set temperature. The first hour is indicated in minutes and seconds "MM:SS" and subsequent time is indicated in hours and minutes "HH:MM" for the first 24 hours. After 24 hours the time is displayed in days and fractions of a day "DD.DD". The timer stops after 30.00 days. The time a bag is held at the set temperature will remain in memory until a new bag is placed in the ivNow.

ivNow Adjustment

Display the firmware version

Press and hold the POWER button for 10 seconds. Press the POWER button to return to operation.

Temperature unit selection

Press and hold the POWER button for 20 seconds or until the current unit (default of °C) is displayed. When displayed, press the STATUS button to toggle the temperature unit between °C and °F. Press POWER to accept the change.

Heated residence time limit

Press and hold the POWER button for 30 seconds or until the current limit (default of 15) is displayed. When displayed, press the STATUS button to select a date range between 7 and 60 days in 1 day increments. Press the POWER button to accept the change.

Temperature set point

Press and hold the POWER button for 40 seconds or until the current set point (default of 40 °C or 104°F) is displayed. When displayed, press the STATUS button to select desired temperature set point between 35°C and 40°C (95°F and 104°F) in 1 degree increments. Press the POWER button to accept the change.

Cleaning and Preventative Maintenance



The cleanliness and appearance of this equipment will contribute considerably to its operating efficiency. Make certain the module is kept free of any debris that may accumulate. Good equipment that is kept clean works better and lasts longer.

Clean the Unit Regularly:

1. Turn the unit off.
2. Disconnect the module from the power source.
3. Wipe the metal, plastic, control surfaces, and sensor switch of the module with a cloth dampened with isopropyl alcohol or 10% bleach solution to clean and disinfect the unit. Avoid the use of abrasive or corrosive cleaning compounds. Avoid contact with the electrical connections and electrical components.
4. Wipe surfaces with a cloth dampened with clean, warm water.
5. Wipe dry with a clean cloth. Always follow appropriate state or local health (hygiene) regulations regarding all applicable cleaning and sanitation requirements.



NOTE: In the event that fluid should spill inside the module, unplug the unit to prevent an electrical shock hazard. Wipe excess fluid from module immediately. Refer to qualified service personnel. Qualified service personnel should remove the module control and remove any remaining liquid. Perform necessary hospital electrical safety checks before returning the unit to operation.

Annual Preventative Maintenance

1. Ensure that the correct Operation and Care Manual is available to all users.
2. Ensure that all users have been properly trained in unit's operation.
3. Inspect condition of plug and cord. Replace if damaged.
4. Clean dust from the unit.
5. Check condition of wall mounting hardware. Ensure mounting screws and assembly are secure.
6. Check control panel overlay condition. Are there any tears or excessive wear on the graphic? Does the control work properly when buttons are pushed?
7. Check that all display LEDs light up. Test by turning the unit off and then on. All LEDs illuminate for one second at start-up.
8. Contact the Pedigo Service department for immediate repair if any problems exist.

WARNING

To prevent serious injury, death, or property damage, **always** disconnect the appliance from the power source before cleaning or servicing.

WARNING

To prevent serious personal injury, death, or property damage:
Do not steam clean, hose down or flood the interior or exterior with water or liquid solution of any kind. Failure to observe this precaution will void the warranty.

(Listed as Ordinary Equipment.)



If your unit is not operating properly, check the following before calling your authorized service agent. Check the power applied to the unit. Is the plug in the outlet? Check to make sure the power is on by pressing the power button on the front of the unit. If it is a multi-pod unit, are the jumper cords between each pod fully inserted?

Do not attempt to repair or service beyond this point. Repairs made without prior authorization by manufacturer will void the warranty on the unit.

This chart is provided for the assistance of qualified technicians only and is not intended for use by untrained or unauthorized service personnel.

Troubleshooting Guide

Code	Refers to	Action Required
E-10	Temperature sensor 1 short	<ol style="list-style-type: none"> 1. Press the status button to clear the error code. 2. If the error persists, contact service.
E-11	Temperature sensor 1 open	
E-20	Temperature sensor 2 short	
E-21	Temperature sensor 2 open	
E-P0	Plate temperature sensor short	
E-P1	Plate Temperature sensor open	
E-98	Temperature delta error - Temperature of fluid bag sensors 1 and 2 differ by more than 3.3°C (6°F)	<ol style="list-style-type: none"> 1. Remove the fluid bag(s) and allow the warmer to cool. 2. Verify that the fluid bag sensor is clean and operating correctly. 3. Press the status button to clear the error code. 4. Disconnect, and then reconnect power to the unit. 5. If the error persists, contact service.
E-31	Product over temperature and the warmer has been actively heating	<ol style="list-style-type: none"> 1. Press the status button to clear the error code. 2. Remove the fluid bag(s) and allow the warmer to cool. Inspect the fluid and discard if necessary. 3. If the error persists, contact service.
E-50	Analog to digital convertor error	<ol style="list-style-type: none"> 1. Press the status button to clear the error code. 2. Remove the fluid bag(s) and allow the warmer to cool. Inspect the fluid and discard if necessary. 3. If the error persists, a qualified service technician should replace the lower control assembly. Contact service.
E-FO	Flash write error	
E-F1	Flash erase error	
E-F2	Flash value error	<ol style="list-style-type: none"> 1. Press the status button to clear the error code. 2. This error is acceptable upon initial start up. The warmer will self-correct.
E-70	Low voltage flag triggered	<ol style="list-style-type: none"> 1. Measure the outlet voltage. Inspect the voltage rating on equipment rating tag. Make sure both voltages match. 2. If the error persists, a qualified service technician should replace the lower control assembly. Contact service.
E-B0	PCB Sensor short	Contact service.
E-B1	PCB Sensor open	
E-B2	PCB Sensor over temperature	
E-79	Input voltage high	A qualified service technician should check the input voltage to ensure it is at or below 277VAC.
E-78	Input voltage low	A qualified service technician should check the input voltage to ensure it is at or above 85VAC.
E179	Input voltage open	Contact service.
E178	Input voltage short	Contact service.
The warmer does not power on		<ol style="list-style-type: none"> 1. Verify that the warmer is plugged into an appropriate outlet 2. Measure the outlet voltage. Inspect the voltage rating on equipment rating tag. Make sure both voltages match. 3. Allow the warmer to cool to reset the protective devices. 4. Inspect the fuses. Replace if blown. 5. If warmer still does not power on, contact service.
Warmer powers on and off when product is loaded and the power switch is ON (I)		<ol style="list-style-type: none"> 1. Remove the warmer from operation. 2. Contact service.
Warmer reads a temperature without a bag of fluid in the contoured warming module		<ol style="list-style-type: none"> 1. Inspect the sensor switch. 2. If the sensor switch is sticking, clean the sensor switch with a dampened isopropyl alcohol wipe and use compressed air to blow out the area. 3. If the warmer still displays a temperature, contact service.



4000 SE Columbia Way • Vancouver, Washington 98661
800.822.3501 • FAX 360.696.1700 • www.pedigo-usa.com



Specifications are subject to change without notice.